



JAPAN AUTOMOBILE FEDERATION

社団法人 日本自動車連盟

JAF公認番号 T-225

グループ T

発効年月日 1975年1月31日

F. I. A. Recognition No.

Group 5588-1

FEDERATION INTERNATIONALE DE L'AUTOMOBILE

Form of recognition in accordance with Appendix J to the International Sporting Code.

国際スポーツ法典付則J項及びF.I.A.万国自動車連盟規則付則J項を認許書式

Manufacturer 製造会社名	NISSAN MOTOR CO., LTD.	Cylinder-capacity 汽缸容量	Reciprocation 2,565 cm ³ 156.5 cu in
Serial No of chassis 製造開始年月式番号	GR(L)S30-000001	Model 型式及び商標名	Special cm ³ cu in
engine エンジン型式	L26-000001	Manufacturer	GR(L)S30 DATSUN 260Z 2+2
Recognition is valid from	1. 4. 75	Manufacturer	NISSAN
		List	NISSAN

The manufacturing of the model described in this recognition form was started on DEC, 1973 and the maximum production of 5,000 identical cars, in accordance with the specifications of this form was reached on AUG, 1974

Photograph A. 3/4 view of car from front 写真A. 全体写真(前3/4方)



The vehicle described in this form has been subject to the following amendments :

Variants

on	19	rec No.	List
on	19	rec No.	List
on	19	rec No.	List
on	19	rec No.	List
on	19	rec No.	List

Normal evolution of the type

on	19	rec No.	List
on	19	rec No.	List
on	19	rec No.	List
on	19	rec No.	List
on	19	rec No.	List

Stamp and signature of the JAF

JAF公認印及び署名

難波靖治

Yasuharu Nanba

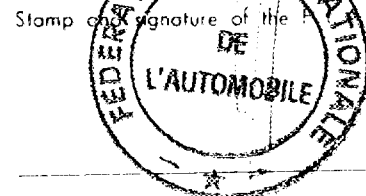
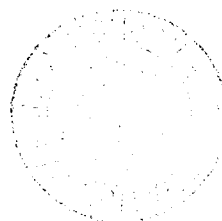

Make NISSAN

Model GR(L)S30
型式

F.I.A. Rec. No.

IMPORTANT - the underlined items must be stated in two measuring systems, one of which must be the metric system. See conversion table hereafter.

CAPACITIES AND DIMENSIONS
仕様諸元

1	<u>Wheelbase</u> ホイールベース	260.5	cm	102.5	inches
2	<u>Front track</u> フレッド(前)	135.5	cm	53.3	inches
3	<u>Rear track</u> フレッド(後)	134.5	cm	52.9	inches
4	Overall length of the car 全長	442.5	cm		
5	Overall width of the car 全幅	165.0	cm		
6	Overall height of the car 全高	129.0	cm		
7	Capacity of fuel tank (reserve included) 燃料タンク容量			65	ltrs
	17.2	Gallon US			Gallon Imp
8	Seating capacity 定員		4		
9	Weight, total weight of the car with normal equipment, water, oil and spare wheel but without fuel nor repair tools 車両重量(冷却水、オイル、スペアタイヤを含む標準状態の車両重量、但し燃料、車載工具を除く)	1,110	kg	2,447	lbs

* Differences in track caused by the use of other wheels with different rim widths must be stated when recognition is requested for the wheels concerned

** Specify ground clearance in relation to the track and give drawing of two fixed points of the vehicle's structure at which 車両の標準状態を示すためのサイドメンバー前端及び後端に於ける地上高 measurements are taken.

These ground clearance dimensions are only for information when checking the track and can in no way affect the eligibility of the car

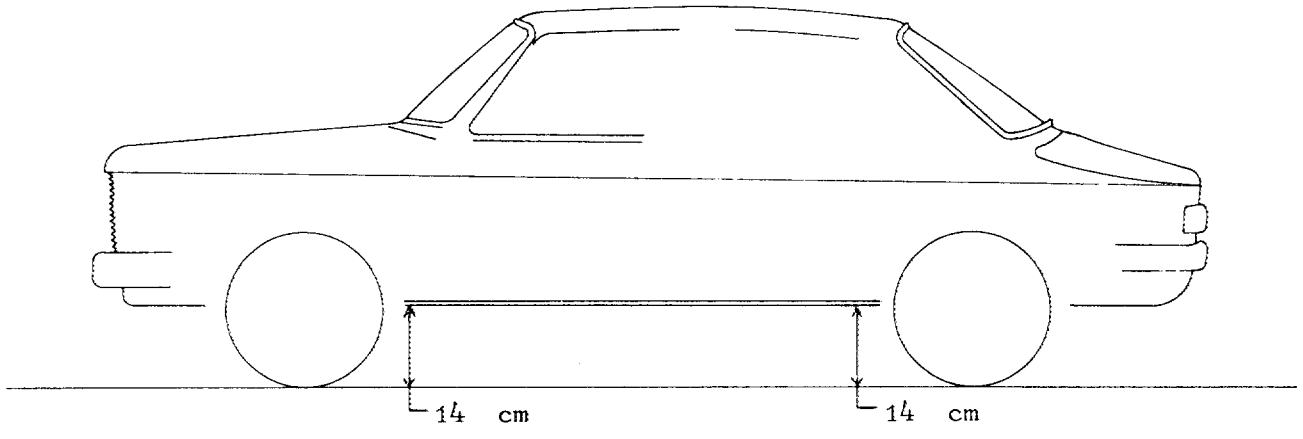

*** Width of the car measured in the vertical plane passing through the axle of the wheels.

車軸上の車体幅	Front フロント	162.4	cm	Rear リヤ	165.0	cm
---------	---------------	-------	----	------------	-------	----

CONVERSION TABLE

1 inch / pouce	= 2.54 cm	1 quart US	= 0.9464 ltrs
1 foot / pied	= 30.4794 cm	1 pint (pt)	= 0.568 ltrs
1 square inch / pouce carre	= 6.452 cm ²	1 gallon imp.	= 4.546 ltrs
1 cubic inch / pouce cube	= 16.387 cm ³	1 gallon US	= 3.785 ltrs
1 pound / livre (lb)	= 453.593 gr.	1 hundred weight (cwt)	= 50.802 kg



Make NISSAN

Model GR(L)S30
型式

F.I.A. Rec. No.

CHASSIS AND COACHWORK (Photographs A, B and C)

- シャシー、ボディ
20. Chassis/body construction : ~~XXXXXX~~ / unitary construction
シャシー/ボディの構造 ~~XXXXXX~~ / 一体構造
21. Unitary construction, material (s) : Steel
一体構造の場合その材質
22. Separate constructions, material(s) of chassis :
セパレート構造の場合その材質
23. Material (s) of coachwork :
ボディの材質
24. Number of doors : 2 Material (s) : Steel
ドアの数 材質
25. Material (s) of bonnet : Steel
ボンネットの材質
26. Material (s) of boot lid : Steel
トランクリッドの材質
27. Material (s) of rear-window : Glass
リアウインドーの材質
28. Material (s) of windscreen : Glass (LAMINATED)
フロントウインドーの材質
29. Material (s) of front-door windows : Glass
フロントドアウインドーの材質
30. Material (s) of rear-door windows :
リアドアウインドーの材質
31. Sliding system of door windows : Vertical, manual
ドアウインドーの開閉方式
32. Material (s) of rear-quarter light : Glass
リアクォーターウインドーの材質

ACCESSORIES AND UPHOLSTERY
アクセサリ

38. Interior heating : yes - ~~XXX~~
39. Air-conditioning : ~~XXX~~ - no
40. Ventilation : yes - ~~XXX~~
41. Front seats, type of seats and upholstery : Separate, Vinyl
フロントシートの形式と表張りの材質
42. Weight of front seat (s), complete with supports and rails, out of the car :
フロントシートの重量 (ブラケット、シートレール付) 7 X 2 kg
43. Rear seats, type of seats and upholstery : Bench, Vinyl
リアシートの形式と表張りの材質
44. Front bumper, material (s) : Steel Weight : 6.2 kg
フロントバンパーの材質 重量
45. Rear bumper, material (s) : Steel Weight : 6.3 kg
リアバンパーの材質 重量

WHEELS
ホイール

50. Type : Pressed steel
形式
51. Weight (per wheel, without tyre) : 7.5 kg
重量
52. Method of attachment : 4 Nuts
取付け方法
53. Rim diameter : 355 mm 14 inches
リム径
54. Rim width : 127 mm 5 inches
リム幅

STEERING
ステアリング

60. Type : Rack and pinion
形式
61. Servo-assistance : ~~XXXX~~ - no
パワーステアリング ~~XXX~~ - 無
62. Number of turns of steering wheel from lock to lock : 2.7
ロックツーロック
63. In case of servo-assistance



Make NISSAN

Model GR(L)S30
型式

J.A.F.公認番号 T-225

F.I.A. Rec. No.

SUSPENSION

サスペンション

- | | |
|---|----------------------|
| 70. Front suspension (photogr. D), type
フロントサスペンションの形式 | Mcpherson |
| 71. Type of spring
スプリングの種類 | Coil |
| 72. Stabiliser (if fitted)
スタビライザーの形式 | Torsion bar |
| 73. Number of shockabsorbers
ショックアブソーバーの数 | 2 |
| 74. Type
形式 | Hydraulic telescopic |
| | |
| 78. Rear suspension (photogr. E), type
リアサスペンションの形式 | Mcpherson |
| 79. Type of spring
スプリングの種類 | Coil |
| 80. Stabiliser (if fitted)
スタビライザーの形式 | Torsion bar |
| 81. Number of shockabsorbers
ショックアブソーバーの数 | 2 |
| 82. Type
形式 | Hydraulic telescopic |

BRAKES (photographs F and G)

ブレーキ

- | | |
|---|-----------|
| 90. System
作動方式 | Hydraulic |
| 91. Servo-assistance (if fitted), type
サーボシステムの形式 | Vacuum |
| 92. Number of hydraulic master cylinders
マスターシリンダーの数 | 1 |

	FRONT フロント		REAR リア	
93. Number of cylinders per wheel ホイール当りのシリンダー数	2		1	
94. Bore of wheel cylinder (s) ホイールシリンダーの内径	54.0	mm	22.2	mm
Drum Brakes ドラムブレーキ				
95. Inside diameter ドラムの内径		mm	229	mm
96. Length of brake linings ライニングの長さ		mm	220	mm
97. Width of brake linings ライニングの幅		mm	40	mm
98. Number of shoes per brake ブレーキ当りのシューの数			2	
99. Total area per brake 1ブレーキ当りの総摩擦面積		mm ²	17,600	mm ²
Disc brakes ディスクブレーキ				
100. Outside diameter ディスクの外径	271	mm		mm
101. Thickness of disc ディスクの厚さ	13	mm		mm
102. Length of brake linings パッドの長さ	78	mm		mm
103. Width of brake linings パッドの幅	52	mm		mm
104. Number of pads per brake ブレーキ当りのパッドの数	2			
105. Total area per brake 1ブレーキ当りの総摩擦面積	7,620	mm ²		mm ²



Make NISSAN

Model GR(L)S30
型式

F.I.A. Rec. No.

ENGINE (photographs J and K) **

130. Cycle		4		
131. Number of cylinders		6		
132. Cylinder arrangement		In-line		
133. Bore		83.0	mm	3.27 inches
134. Stroke		79.0	mm	3.11 inches
135. Capacity per cylinder		427.5	cm ³	26.088 cu. in.
136. Total cylinder-capacity		2,565	cm ³	156.53 cu. in.
137. Material (s) of cylinder block		Cast-Iron		
138. Material (s) of sleeves (if fitted)				
139. Cylinder-head, material (s)	Aluminum-cast	Number fitted		1
140. Number of inlet ports		6		
141. Number of exhaust ports		6		
142. Compression ratio		8.6		
143. Volume of one combustion chamber		56.2	cm ³	
144. Piston, material		Aluminum-cast		
145. Number of rings		3		
146. Distance from gudgeon pin centre line to highest point of piston crown		38.1	mm	
147. Crankshaft :		cast iron / stamped		
148. Type of crankshaft :		integral / integral		XXXXXX
149. Number of crankshaft main bearings		7		
150. Material of bearing cap		Cast-iron		
151. System of lubrication :		dry sump / oil in sump		
152. Capacity, lubricant		4.7	ltrs	
153. Oil cooler :		yes / no		
154. Method of engine cooling		Water		
155. Capacity of cooling system		9.4	ltrs	
156. Cooling fan (if fitted), dia.		410	mm	
157. Number of blades of cooling fan		8		
Bearings **				
158. Crankshaft main, type	Plain		Dia.	55 mm
159. Connecting rod big end,	Plain		Dia.	50 mm
Weights **				
160. Flywheel (clean)		9.4	kg	
161. Flywheel with clutch (all turning parts)		16.1	kg	
162. Crankshaft		21.9	kg	
163. Connecting rod		0.64	kg	
164. Piston with rings and pin		0.53	kg	



** for additional information concerning Wankel rotary engines see page
ロータリーエンジンは 参照

Make NISSAN

Model GR(L)S30
型式

F.I.A. Rec. No.

FOUR STROKE ENGINES * , * *

4サイクルエンジン

- | | |
|--|---------------|
| 170. Number of camshafts
カムシャフトの数 | 1 |
| 171. Location
カムシャフトの位置 | Cylinder head |
| 172. Type of camshaft drive
カムシャフトの駆動方式 | Chain |
| 173. Type of valve operation
バルブの作動方式 | Rocker arm |

INLET (see page 8) * , * *
吸気系

- | | |
|---|------------------------------------|
| 180. Material(s) of inlet manifold
マニホールドの材質 | Aluminum alloy |
| 181. Diameter of valves
バルブの径 | 42 mm 1.65 inches |
| 182. Max. valve lift
バルブリフト | 10.5 mm 0.41 inches |
| 183. Number of valve springs
バルブスプリングの数 | 2 |
| 184. Type of spring
バルブスプリングの種類 | Coil |
| 185. Number of valves per cylinder
シリンダー当りのバルブの数 | 1 |
| 186. Tappet clearance for checking timing (cold) | 0.25 mm |
| 187. Valves open at (with tolerance for tappet clearance indicated)
バルブ開き始め | B.T.D.C $16^{\circ} \pm 3^{\circ}$ |
| 188. Valves close at (with tolerance for tappet clearance indicated)
バルブ閉じ終り | A.B.D.C $52^{\circ} \pm 3^{\circ}$ |
| 189. Air filter, type
エアークリーナーの形式 | Dry |

EXHAUST (see page 8) * , * *
排気系

- | | |
|---|------------------------------------|
| 195. Material (s) of exhaust manifold
マニホールドの材質 | Cast-iron |
| 196. Diameter of valves
バルブの径 | 35 mm 1.38 inches |
| 197. Max. valve lift
バルブリフト | 10.5 mm 0.41 inches |
| 198. Number of valve springs
バルブスプリングの数 | 2 |
| 199. Type of spring
バルブスプリングの種類 | Coil |
| 200. Number of valves per cylinder
シリンダー当りのバルブ数 | 1 |
| 201. Tappet clearance for checking timing (cold) | 0.25 mm |
| 202. Valves open at (with tolerance for tappet clearance indicated)
バルブ開き始め | B.B.D.C $54^{\circ} \pm 3^{\circ}$ |
| 203. Valves close at (with tolerance for tappet clearance indicated)
バルブ閉じ終り | A.T.D.C $14^{\circ} \pm 3^{\circ}$ |

CARBURETION (photograph N)
気化器

- | | |
|---|------------|
| 210. Number of carburetors fitted
キャブレターの数 | 2 |
| 211. Type
形式 | Side-draft |
| 212. Make
製造会社 | HITACHI |
| 213. Model
型式 | HMB46W |
| 214. Number of mixture passages per carburettor
キャブレター当りのバルブ数 | 1 |
| 215. Flange hole diameter of exit port(s) of carburettor
キャブレター出口内径 | 46 mm |
| 216. Minimum dimensions of mixture pasage(s)
with piston at max. height (example: SU)
ベンチュリーの最小寸法 (SUなどはピストン最上部で測定) | 34 mm |

*) for additional information concerning two-stroke engines and super-charged engines see page
2サイクルエンジン、過給機付エンジンは 頁参照

* *) for additional information concerning Wankel rotary engines see page
ロータリーエンジンは 頁参照

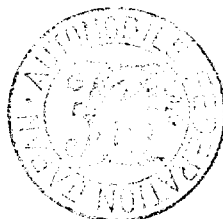

Make NISSAN

Model GR(L)S30
型式

J.A.F公認番号 T-225

F.I.A. Rec. No.

INJECTION (if fitted)
燃料噴射

- 220. Make of pump
ポンプの製造会社
- 221. Number of plungers
プランジャーの数
- 222. Model or type of pump
ポンプの型式
- 223. Total number of injectors
ノズルの総数
- 224. Location of injectors
ノズルの位置
- 225. Minimum diameter of inlet pipe
吸気管の最小径 mm

ENGINE ACCESSORIES
エンジン補機

- 230. Fuel pump :
燃料ポンプ mechanical and / ~~or~~ electric
機械式 / 電気式
- 231. No. fitted
ポンプの数 2
- 232. Type of ignition system
点火方式 Make & break
- 233. No. of distributors
ディストリビューターの数 1
- 234. No. of ignition coils
コイルの数 1
- 235. No. of spark plugs per cylinder / ~~or~~
シリンダー当りのプラグ数 (~~又は~~) 1
- 236. Generator,
発電機 type: ~~or~~ / alternator - number fitted 1
直流 / 交流 数
- 237. Method of drive
駆動方式 V-Belt
- 238. Voltage of generator
発電機電圧 12 volts
- 239. Battery, number
バッテリーの数 1
- 240. Location
バッテリー位置 Engine room
- 241. Voltage of battery
バッテリー電圧 12 volts

ENGINE AND CAR PERFORMANCES (as declared by manufacturer in catalogue)

- 250. Max. engine output 160 ps (type of horsepower: JIS) at 5,400 rpm
- 251. Maximum rpm 6,400 output at that figure 142 ps
- 252. Maximum torque 23.0 kg-m at 4,400 rpm
- 253. Maximum speed of the car 205 km/hour

255. Cam profile
カムプロフィール

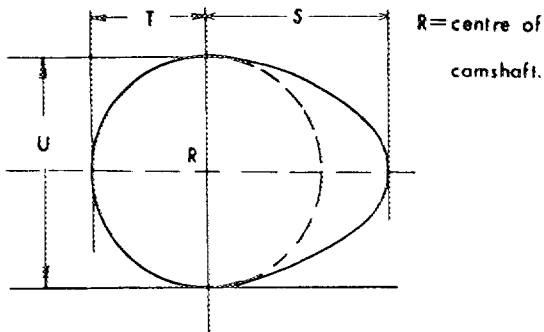

Inlet cam
吸気カム

S =	26.8	mm	1.06	inches
T =	16.6	mm	0.65	inches
U =	33.2	mm	1.31	inches

Exhaust cam
排気カム

S =	26.8	mm	1.06	inches
T =	16.6	mm	0.65	inches
U =	33.2	mm	1.31	inches



Make NISSAN

Model GR(L)S30
型式

F.I.A. Rec. No.

Drawing inlet manifold ports side of cylinder head ~~showing~~ scale or dimensions and manufacturing tolerance

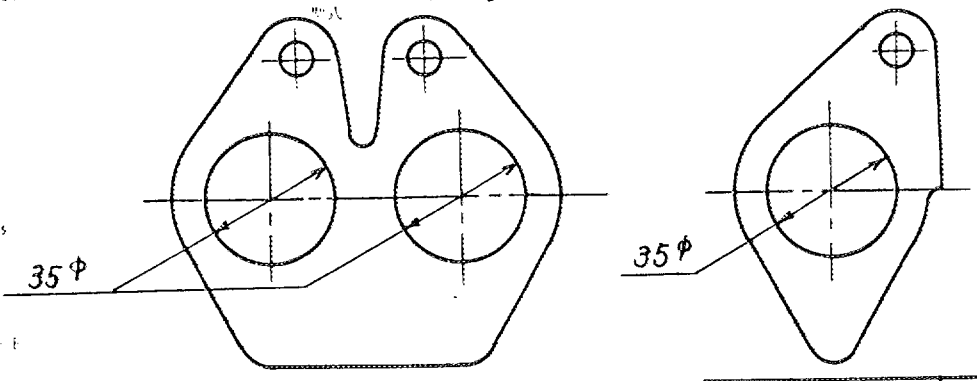

Drawing of entrance to inlet port of cylinder head ~~showing~~ scale or dimensions and manufacturing tolerance

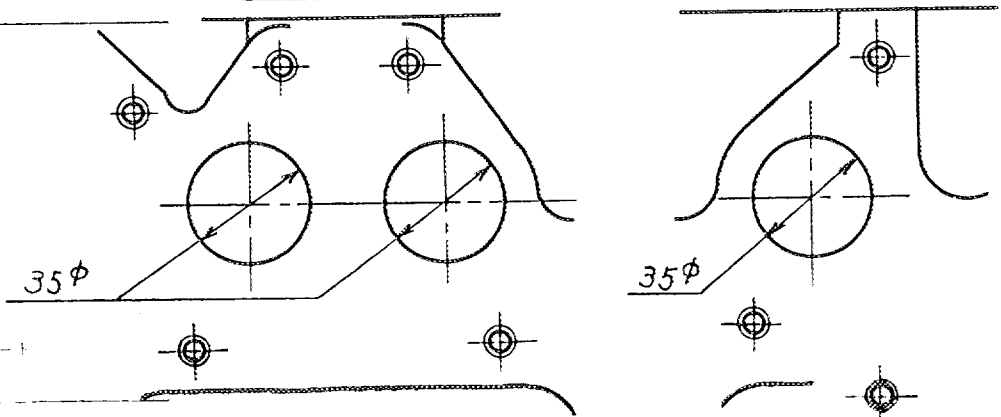

Drawing exhaust manifold ports, side of cylinder head. ~~showing~~ scale or dimensions and manufacturing tolerance

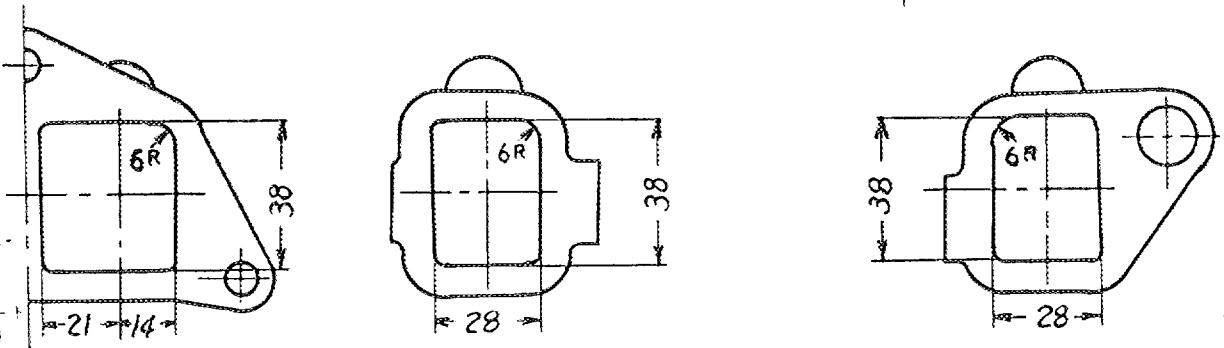

Drawing of exit to exhaust port of cylinder head. ~~showing~~ Indicate scale or dimensions and manufacturing tolerance.

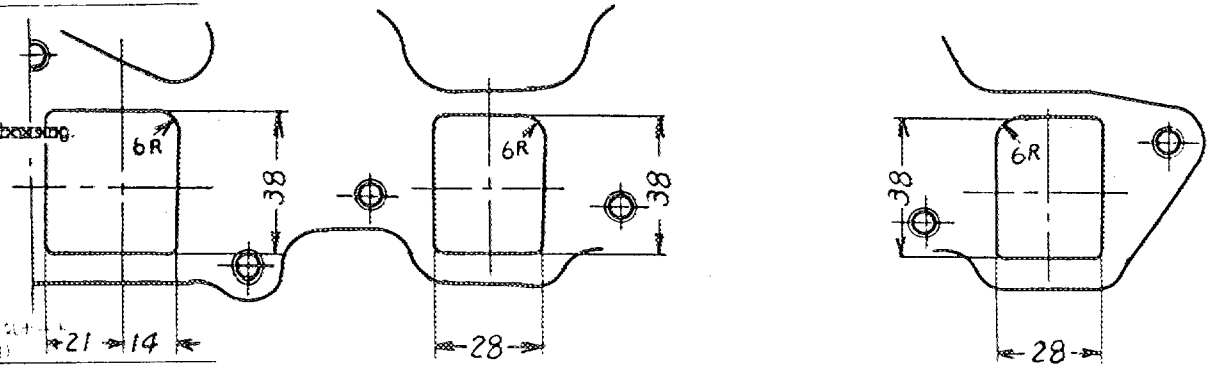

Unit: mm
××××××××
××××××



Make NISSAN

Model GR(L)S30
型式

F.I.A. Rec. No.

DRIVE TRAIN
駆動系

CLUTCH
クラッチ

- 260. Type of clutch 形式 Dry plate
- 261. No of plates プレッシングプレートの数 1
- 262. Dia. of clutch plates 227 mm プレッシングプレートの外径
- 263. Dia. of linings, inside 150 mm フェーリングの内径
- 264. Method of operating clutch 作動方式 Hydraulic

GEAR BOX (photograph H)
トランスミッション

- 270. Manual type, make NISSAN 手動式の製造会社名 Method of operation Mechanical 作動方式
- 271. No of gear-box ratios forward 5 前進段数
- 272. Synchronized forward ratios 1, 2, 3, 4 & 5
- 273. Location of gear-shift フットレバーの位置 Floor
- 274. Automatic, make NISSAN 自動式の製造会社名 type 3N71B 形式
- 275. No. of forward ratios 3 前進段数
- 276. Location of gear-shift フットレバーの位置 Floor

277.	Manual 手動		Automatic 自動		Alternative manual 代替手動		Alternative automatic 代替自動	
	Ratio ギヤ比	No. teeth 歯数	Ratio ギヤ比	No. teeth 歯数	Ratio ギヤ比	No. teeth 歯数	Ratio ギヤ比	No. teeth 歯数
1	3.32	$\frac{31 \times 33}{22 \times 14}$	2.46	$2 + \frac{33}{72}$	2.82	$\frac{31 \times 32}{22 \times 16}$		
2	2.08	$\frac{31 \times 27}{22 \times 20}$	1.46	$1 + \frac{33}{72}$	1.97	$\frac{31 \times 28}{22 \times 20}$		
3	1.31	$\frac{31 \times 26}{22 \times 28}$	1.00		1.47	$\frac{31 \times 24}{22 \times 23}$		
4	1.00				1.19	$\frac{31 \times 22}{22 \times 26}$		
5	0.86	$\frac{31 \times 19}{22 \times 31}$			1.00			
6								
reverse リバース	3.38	$\frac{31 \times 23 \times 36}{22 \times 15 \times 23}$	2.18	$\frac{72}{33}$	3.38	$\frac{31 \times 23 \times 36}{22 \times 15 \times 23}$		

- 278. Overdrive, type オーバードライブ形式
- 279. Forward gears on which overdrive can be selected オーバードライブの作動段数
- 280. Overdrive ratio オーバードライブ比

FINAL DRIVE
ファイナル

- 290. Type of final drive 形式 Hypoid gear
- 291. Type of differential 差動機形式 Bevel gear
- 292. Type of limited slip differential (if fitted) リミテッドスリップデフの形式 Friction
- 293. Final drive ratio 3.36 3.90
ギヤ比
Number of teeth 37/11 39/10
歯数



Make NISSAN

Model GR(1)S30

F.I.A. Rec. No.

REBORING DIMENSION

* Max Bore	83.3 mm	3.28 inches
** Max Capacity Per Cylinder	430.5 cm ³	26.27 cu.in
*** Max Total Cylinder Capacity	2,583 cm ³	157.62 cu.in

COMBUSTION CHAMBER

* Volume of one combustion chamber of cylinder head	47.8 cm ³	2.92 cu.in
** Thickness of cylinder headgasket when compressed.	1.2 mm	

Original equipment affecting preceding information. This to be stated together with reference number.

The following items have been added for group 1.

REAR DISC BRAKE

93. Number of cylinders per wheel	1
100. Outside diameter	269 mm
101. Thickness of disc	10 mm
102. Length of brake linings	43 mm
103. Width of brake linings	53 mm
104. Number of pads per brake	2
105. Total area per brake	4,440 mm ²

Photograph

E, Rear axle complete

G, Rear brake disc with caliper

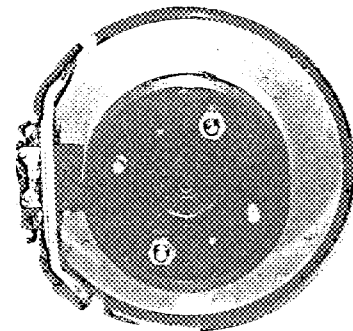
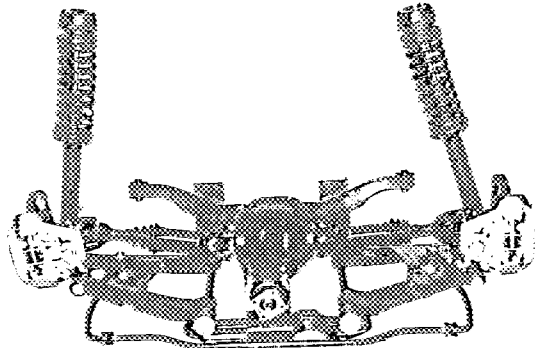

4SPEED GEAR BOX

- 270. Manual type, make
Method of operation
- 271. No. of gear-box ratios forward
- 272. Synchronized forward ratios
- 273. Location of gear-shift

NISSAN
Mechanical
4
1, 2, 3 & 4.
Floor

277	Manual	
	Ratio	No. teeth
1	3.59	$\frac{32}{21} \times \frac{33}{14}$
2	2.25	$\frac{32}{21} \times \frac{28}{19}$
3	1.42	$\frac{32}{21} \times \frac{26}{28}$
4	1.00	
reverse	3.66	$\frac{32}{21} \times \frac{23}{15} \times \frac{36}{23}$

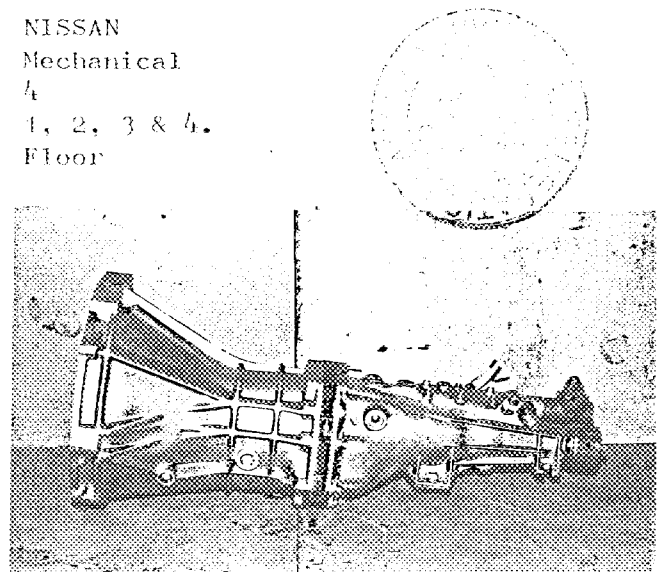

Make NISSAN

Model GR(L)S30

F.I.A. Rec. No.

Photograph

B. 3/4 view of car from rear (右后3/4视图)

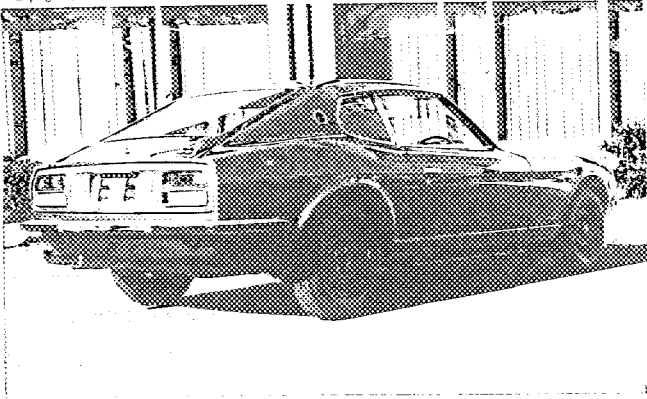

D. Front axle complete, removed from car. Without wheels

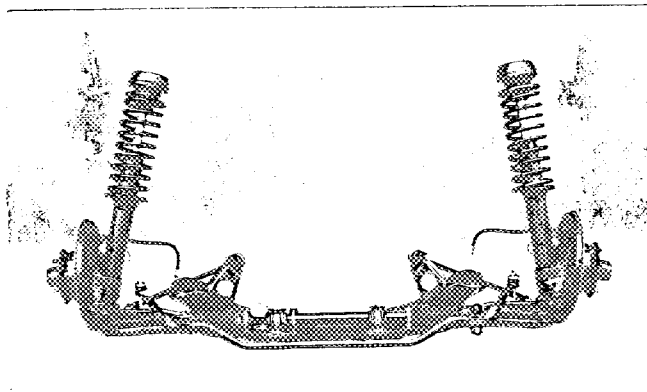

F. Front brake disc with calipers

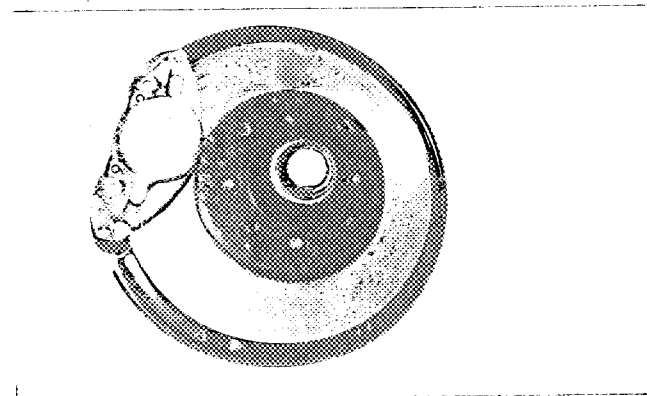

H. Gear-box, view from side (右视图)

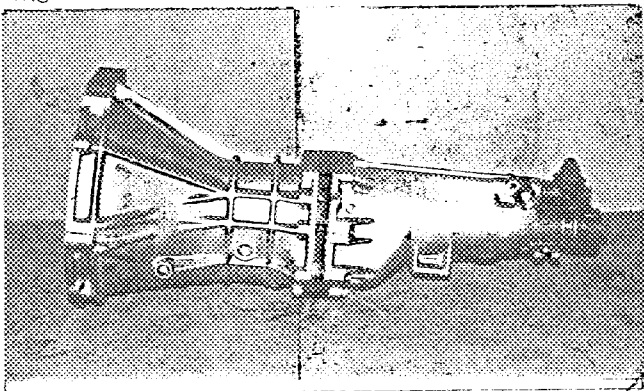

C. Interior view of car through driver's door (open or removed) with dashboard (内饰板附内)

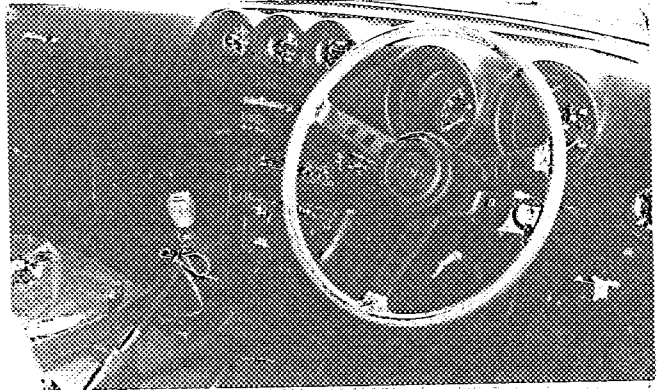

E. Rear axle complete without wheels, removed from car

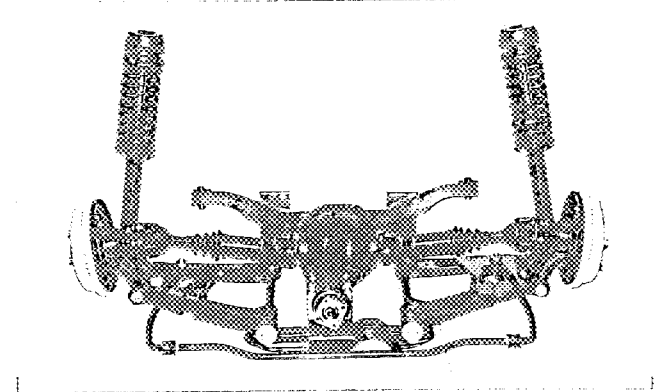

G. Rear brake drum removed

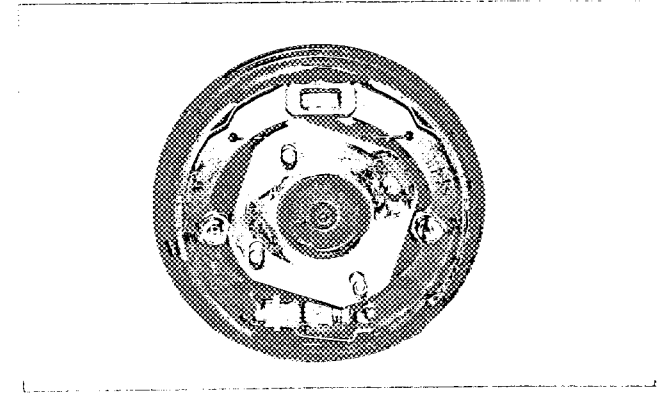

I. Silencer + exhaust pipes after exhaust manifold (排气管)

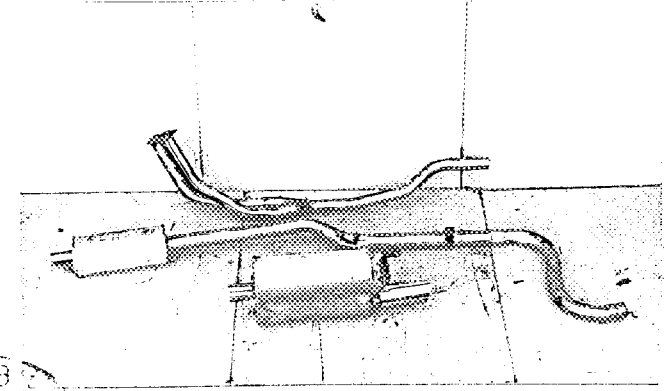

Photograph

J. Engine unit out of car, from right. With clutch and accessories but without air filter nor gear-box.

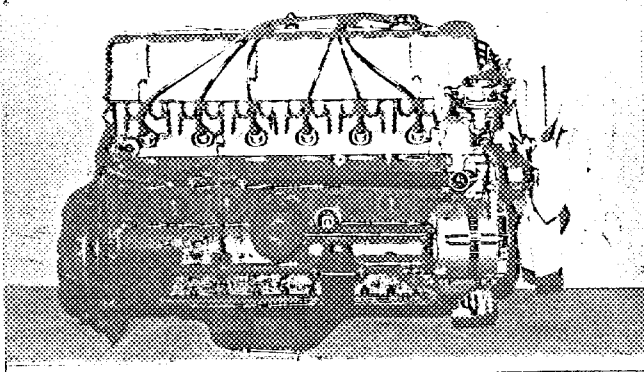

K. Engine unit out of car, from left. With clutch and accessories but without gear-box nor air filter.

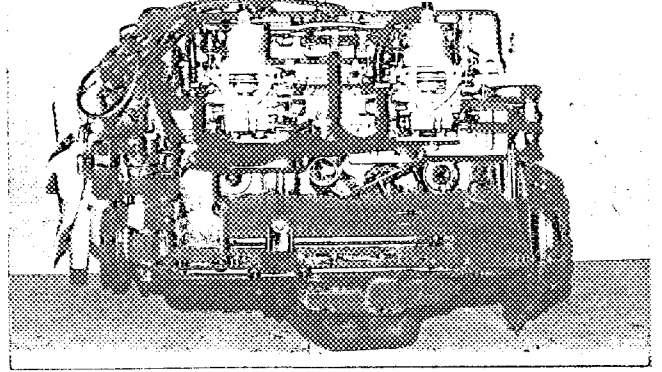

L. Combustion chamber

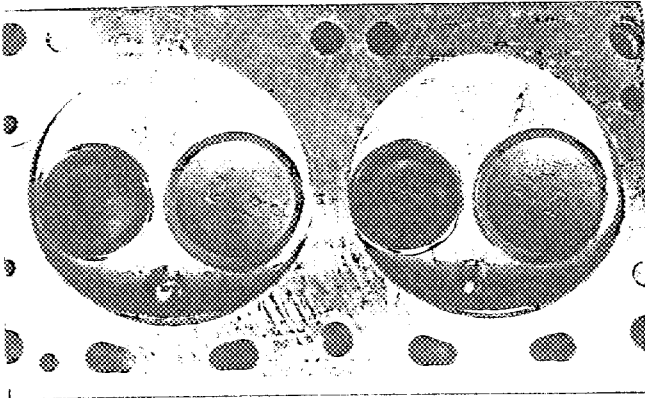

M. Piston crown



N. Carburettor (view from side of manifold)

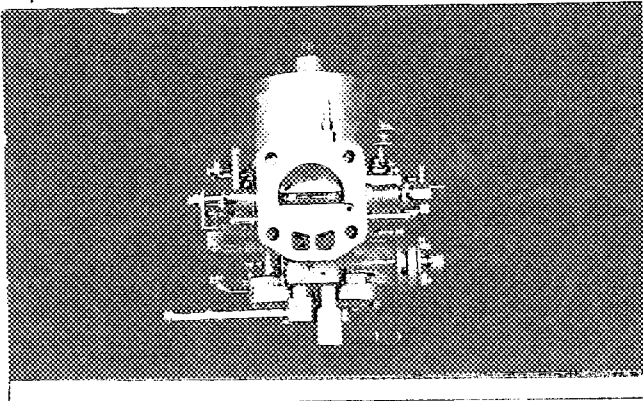

O. Engine in car with all accessories, bonnet open or removed.

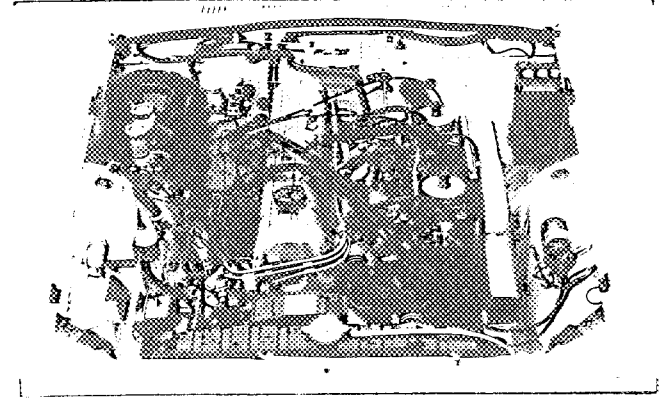

P. Inlet manifold

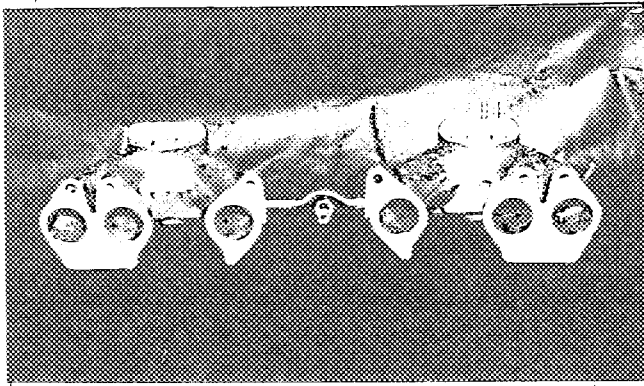

Q. Exhaust manifold

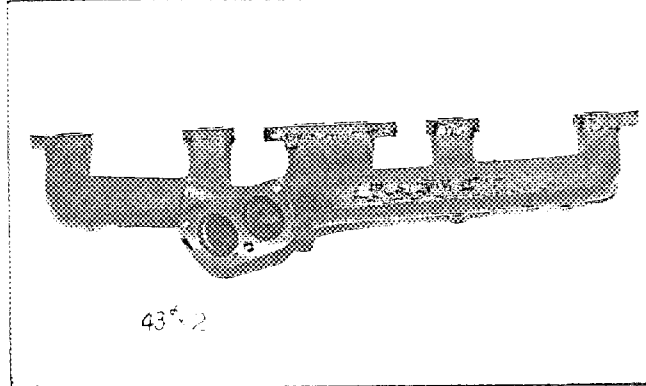

435-2

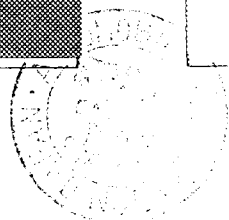

DIMENSIONS OF INTERIOR
車内寸法
(Conform to Art. 253 b of Appendix J)

For four seaters:
4座席

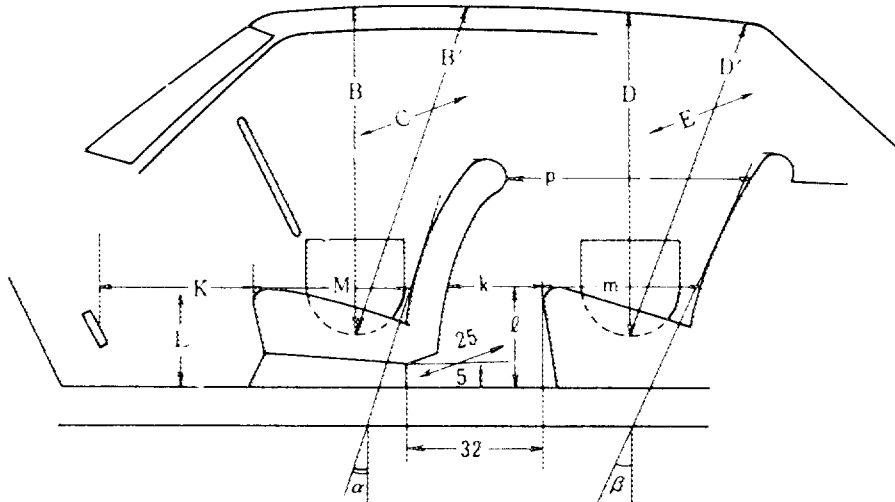

Minimum Dimensions (cm)							
B	B'	α	C	D	D'	β	E
93	97	15°	135	92	95	15°	130

Minimum Dimensions (cm)								
L	l	M	m	k+m	p	k	k+l+m	K+L+M
29	27	53	46	71	64	25	98	122
0.9L = 26.0		0.85M = 45.0		0.85(k+m) = 60.5		(15)	(95)	(120)

For two seaters:
2座席

Minimum Dimensions	
B	C
cm	cm

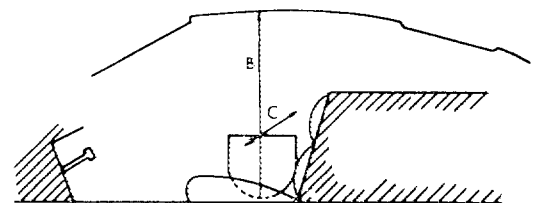



JAPAN AUTOMOBILE FEDERATION

社団法人 日本自動車連盟

J.A.F. 公認番号 T=225 V=2

発効日付 1975年1月31日
F.I.A. Homol. No 5588 1/1V

FEDERATION INTERNATIONALE DE L'AUTOMOBILE

Form of recognition accordance with
Appendix J to the International Sporting Code.

国際汽力競技連盟の承認する以下の競技車両規則に従って承認された。

Make NISSAN MOTOR CO., LTD. 製造会社名	Model GR(L)S30 型式及び商標名	DATSUN 260Z 2+2
Modification's application starts with serial No.	chassis 適用した型式番号 engine 適用した型式	GR(L)S30-000001 L26
Application of this amendment started the 適用日付	JAN. 1974	
Commercial denomination after application of modifications		
The modifications are to be considered as: Variant / XXXXXXXXXXXXXXXXXXXX 型式 / XXXXXXXXXX		
Date amendment is valid from	1 4 75	List

Description of amendment 内容

Optional equipment.

VALID FOR GROUP 2 ONLY

"valable en Groupe 2 uniquement"
"valid for Group 2 only"

ENGINE

Crank shaft

Modifying the number of bolt hole.
Weight 18.5 kg
Parts No. 12200-N3120

Connecting rod

Modifying bolt hole.
Weight 0.64 kg
Parts No. 12100-E4621

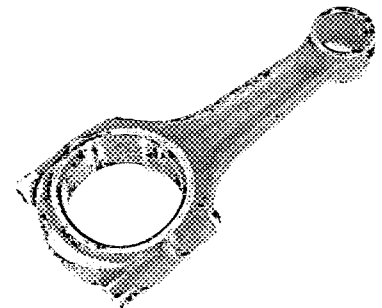
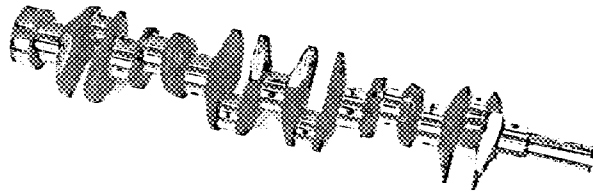

Stamp and signature of the JAF

J.A.F. 承認者署名

難波靖治
Yasuharu Nanba

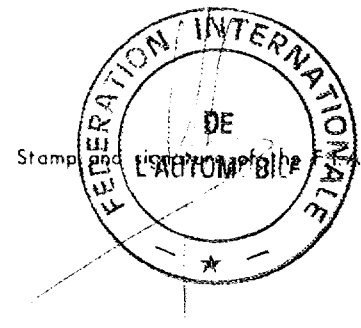
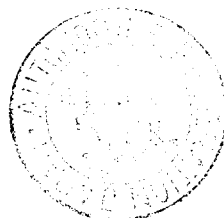

Cylinder-head

Material : Aluminum
Parts No. 11042-E4622

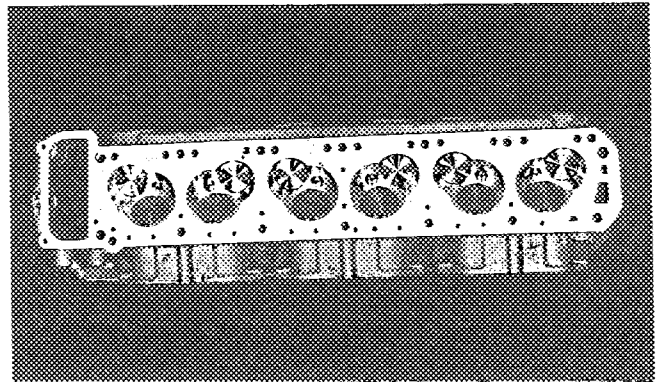
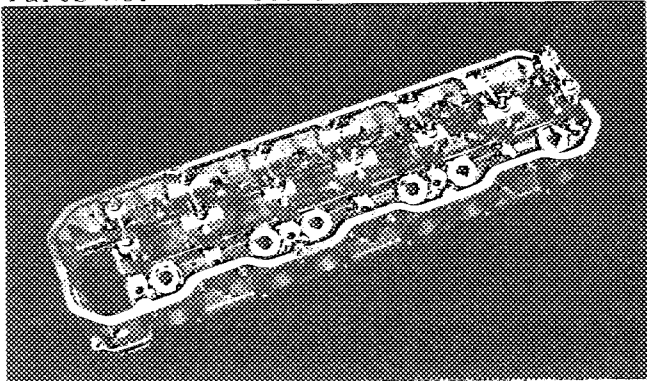

Drawing of entrance to inlet port of cylinder-head
Indicate scale or dimensions and manufacturing tolerance.

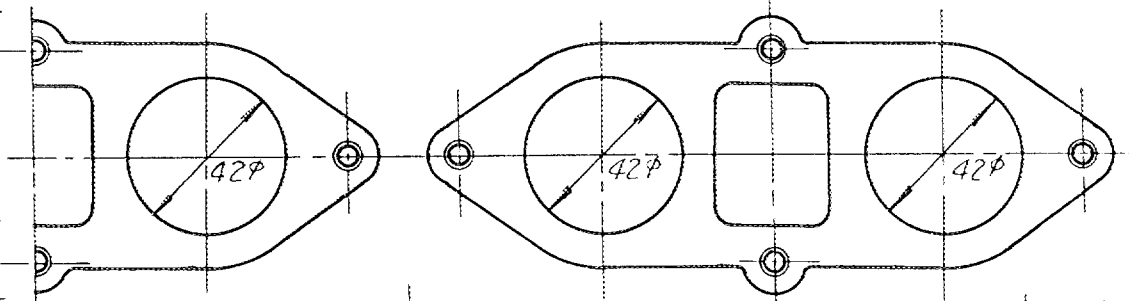

Drawing of exit to exhaust port of cylinderhead
Indicate scale or dimensions and manufacturing tolerance.

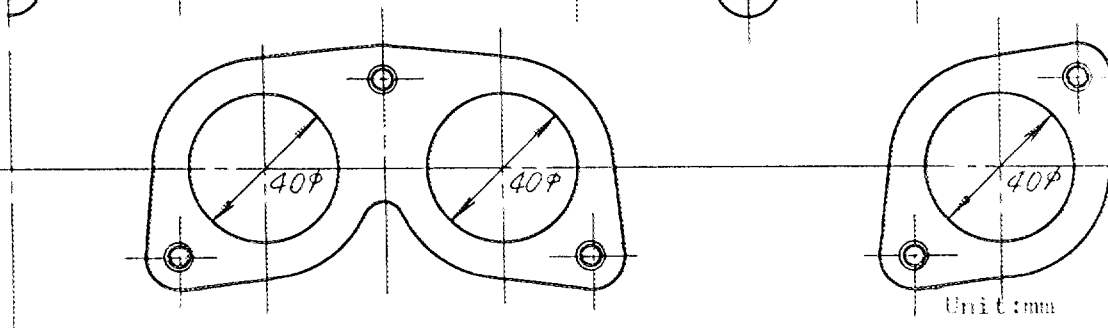

Unit: mm

FLYWHEEL

Modifying the number of bolt hole.
Weight : 7.4 kg
Parts No. 12310-E4621

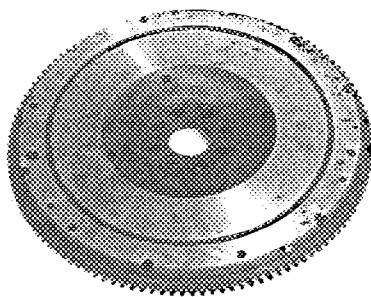

DRY SUMP LUBRICATION

151. System of lubrication: Dry sump
Oil pump Parts No. 15410-N3120

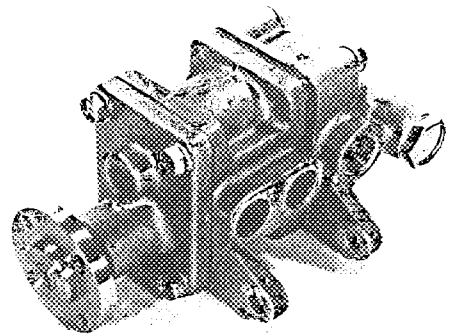

"valable en Groupe 2 uniquement"
"valid for Group 2 only"

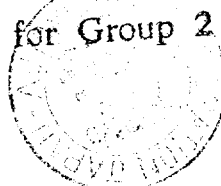

CLUTCH

Single plate clutch cover

Modifying clutch cover
 Weight 5.2 kg
 Parts No. 30210-N3120

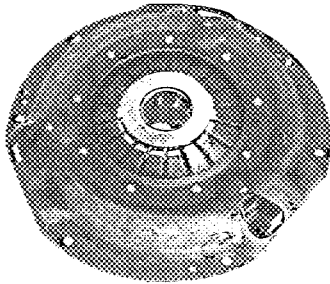

Twin plate clutch

260. Type of clutch	Dry plate
261. No. of plates	2
262. Dia of clutch plates	186 mm
263. Dia of linings, inside	134 mm
Dia of linings, outside	184 mm
264. Method of operating clutch	Hydraulic
Weight	3.2 kg
Parts No.	30200-N3220

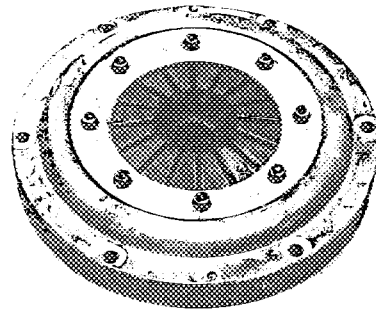

GEAR BOX

277	Manual	
	Ratio	No. teeth
1	3.32	$\frac{31}{22} \times \frac{33}{14}$
2	2.27	$\frac{31}{22} \times \frac{29}{18}$
3	1.60	$\frac{31}{22} \times \frac{25}{22}$
4	1.24	$\frac{31}{22} \times \frac{22}{25}$
5	1.00	
reverse	3.38	$\frac{31}{22} \times \frac{23}{15} \times \frac{36}{23}$

Modifying the rearend of flange type.
 Parts No. 32020-E9605

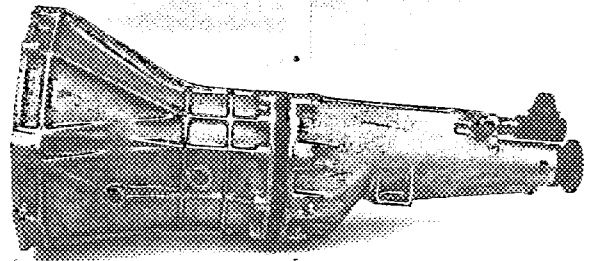

GEAR BOX FRONT CASE

Modifying front case.
 Material Aluminum alloy
 Parts No. 32101-N3020

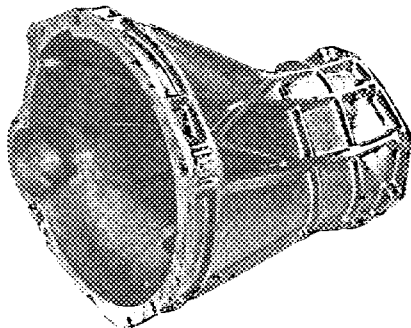

"valable en Groupe 2 uniquement"
 "valid for Group 2 only"

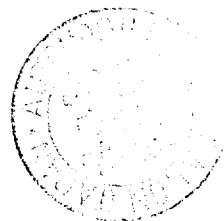

PROPELLER SHAFT

Modifying propeller shaft.
Parts No. 37000-N3720

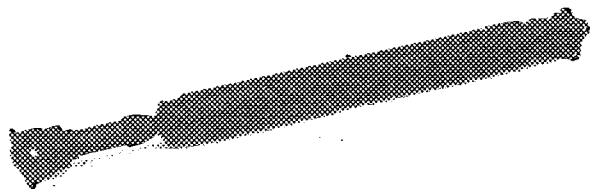

DRIVE SHAFT

Modifying drive shaft.
Parts No. 39600-N3120

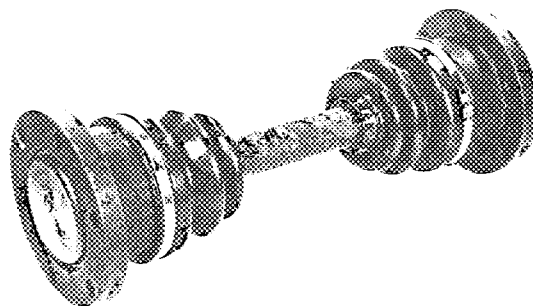

FINAL DRIVE

Modifying the dimensions of gear and case.
293. Final drive ratio 4.11
Number of teeth 37/9
Parts No. 38300-U3400

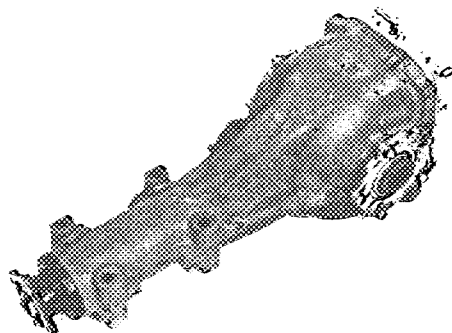

"valable en Groupe 2 uniquement"
"valid for Group 2 only"

SUSPENSION PARTS

Front strut

Modifying the strut of adjustable type.
Parts No. R/H 54302-E4621
L/H 54303-E4621

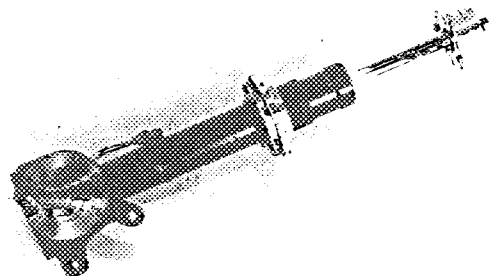

Rear strut

Modifying the strut of adjustable type.
Parts No. 55302-E4621

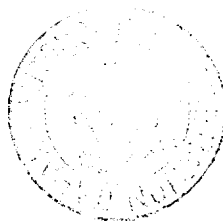
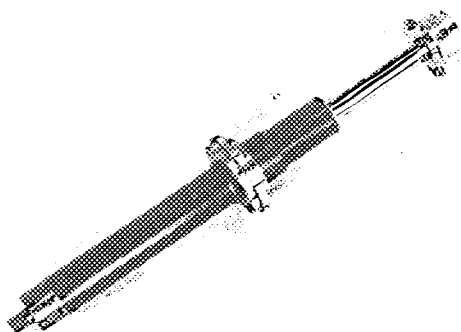

Compression rod

Modifying compression rod with pillow ball.
Parts No. 54470-N3121

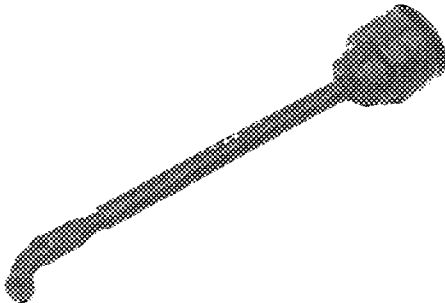

Brace transverse link

Modifying brace transverse link.
Parts No. 55461-E4621



BRAKES

Modifying disc brakes.

- 93. Number of cylinder per wheel
- 94. Bore of wheel cylinder(s)
- 100. Outside diameter
- 101. Thickness of disc
- 102. Length of brake linings
- 103. Width of brake linings
- 104. Number of pads per brake
- 105. Total area per brake

	FRONT		REAR	
	4		4	
	41.3	mm	41.3	mm
	276	mm	276	mm
	20	mm	20	mm
	104	mm	104	mm
	47	mm	47	mm
	2		2	
	9,776	mm ²	9,776	mm ²

Front disc brake

Parts No.
Brake caliper R/H 41000-E4621
Brake caliper L/H 41010-E4621
Brake rotor 40206-N3120

Rear disc brake

Parts No.
Brake caliper R/H 41000-E4621
Brake caliper L/H 41010-E4621
Adapter plate R/H 44155-N3120
Adapter plate L/H 44165-N3120
Brake rotor 43206-N3120

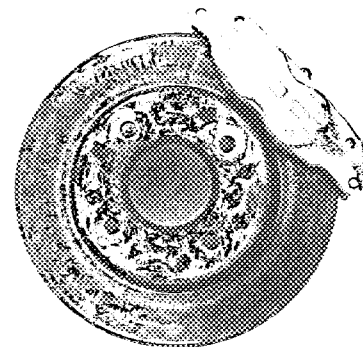
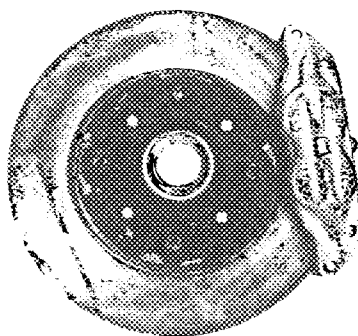

"valable en Groupe 2 uniquement"
"valid for Group 2 only"

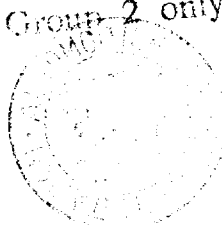

Make NISSAN

Model GR(L)S30

UNDER COVER

Front under protector
Parts No. 98200-E7200

Front under protector
Parts No. 99090-E4175

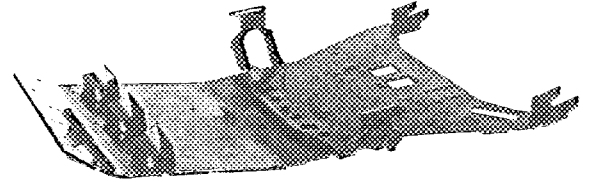
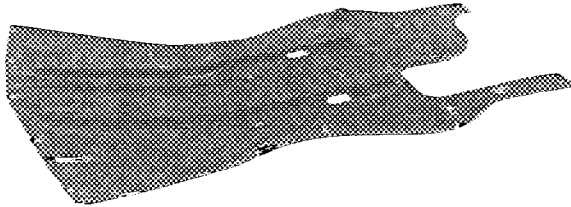

FRONT BUMPER

Parts No. 62650-E8700

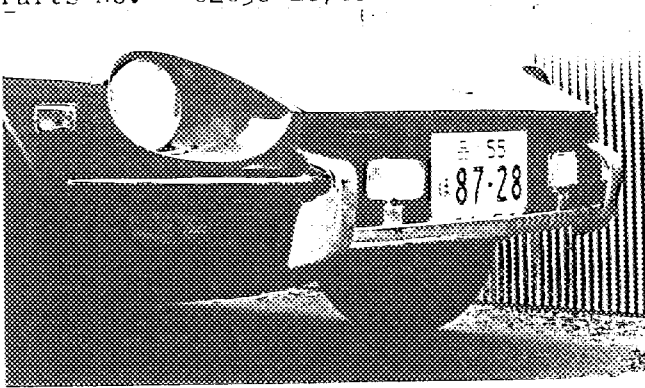

ALTERNATIVE FRONT BUMPER

Material : Steel

"valable en Groupe 2 uniquement"
"valid for Group 2 only"

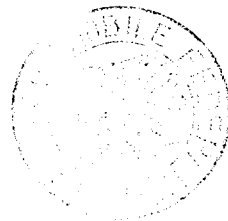



JAPAN AUTOMOBILE FEDERATION

社団法人 日本自動車連盟

J.A.F.公認番号 T-225 V-1

発効年月日 1975年1月31日

F.I.A. Homol. No. 2/1v 5588

FEDERATION INTERNATIONALE DE L'AUTOMOBILE

Form of recognition accordance with Appendix J to the International Sporting Code.

国際スポーツ法典付則J項及びJAF国内競技車両規則に従った公認書式。

Make NISSAN MOTOR CO., LTD.

製造会社名

Model GR(L)S30

型式及び通称名

DATSUN 260Z 2+2

Modification's application starts with serial

No. chassis 適用シャシー型式番号

GR(L)S30-000001

engine 適用エンジンの型式

L26

Application of this amendment started the 適用年月日

DEC, 1973

Commercial denomination after application of modifications

The modifications are to be considered as: Variant / 変更 / ~~XXXXXXXXXXXXXXXXXXXX~~

Date amendment is valid from

1 4 75

List

Description of amendment 内容

The following items have been added for group 1.

CAR WITH AIR SPOILER MODEL

Photograph

A, 3/4 view of car from front

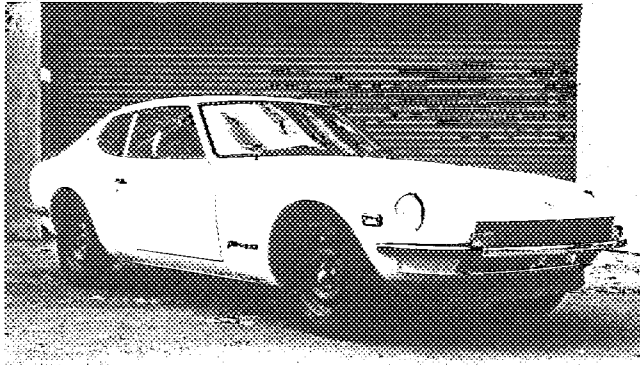

B, 3/4 view of car from rear

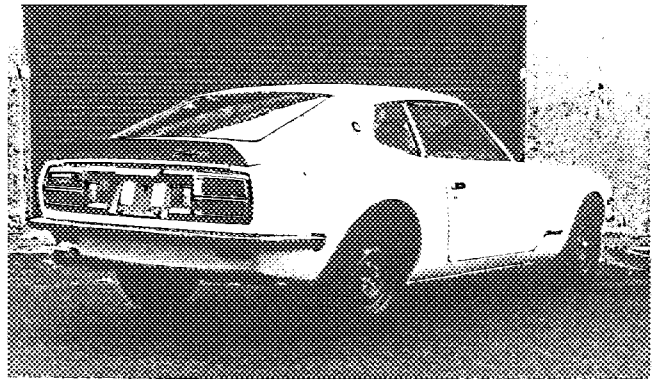

9, Weight, total weight of the car with normal equipment water, oil and spare wheel but without fuel nor repair tools :

1,115 kg

2,458 lbs

Stamp and signature of the JAF

JAF公認印及び署名

難波靖治

Yasuharu Nanba



Stamp and signature of the F.I.A.

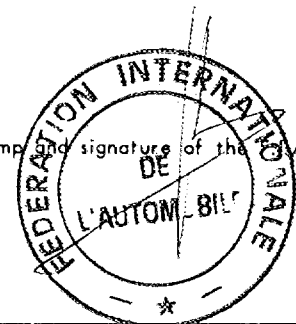



JAPAN AUTOMOBILE FEDERATION

社団法人 日本自動車連盟

J.A.F. 登録番号 T-225V-3
登録年月日 1975年4月30日

F.I.A. Homol. No. 5588

3/2V

FEDERATION INTERNATIONALE DE L'AUTOMOBILE

Form of recognition accordance with
Appendix J to the International Sporting Code.

国際自動車連盟の承認を得た日本国内製自動車競技用自動車承認書

Make	NISSAN MOTOR CO., LTD.	Model	GR(L)S30	DATSUN 260Z 2+2
製造会社名		型式及車種名称		
Modification's application starts with serial	No.	chassis 適用: 1974年型以降	GR(L)S30-000001	
Application of this amendment started the	DEC. 1974	engine 適用: 1974年型以降	L26	
Commercial denomination after application of modifications		GH(L)S30	DATSUN 280Z 2+2	
The modifications are to be considered as:	Variant /	XXXXXXXXXXXXXXXXXXXXXXXXXXXX		
Date amendment is valid from	L7.75	List		

Description of amendment:

The following items have been added.

Applicable to GR(L)S30 model series.

Another type of electrical controlled gasoline injection 2800 cm³ engine can be selected for GR(L)S30 cars as maker's option.

Serial Number of production car will be start from No. GH(L)S30-030001 for chassis and No. L28-000001 for engine.

Photograph

J, Engine unit out of car, from right

K, Engine unit out of car, from left

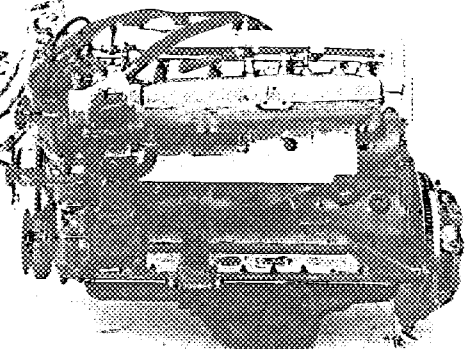
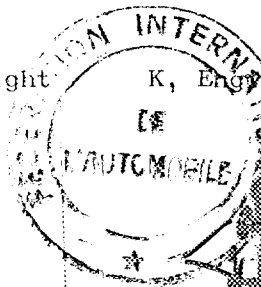
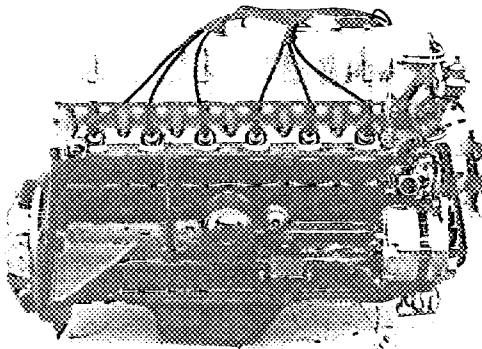

9. Weight, total weight of the car with normal equipment water, oil and spare wheel but without fuel nor repair tools :

1,110 kg

Further detailed specifications different from the original engine are described on the attached sheets.

Stamp and signature of the JAF

J.A.F. 公認競技者

難波靖治

Yasuharu Nanba

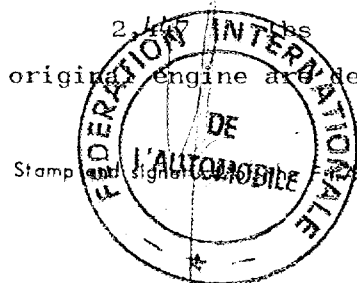

L28 ELECTRONICAL CONTROLLED GASOLINE INJECTION ENGINE SPEC.

133. Bore	86.0 mm	3.39 in
134. Stroke	79.0 mm	3.11 in
135. Capacity per cylinder	458.83 cm ³	28.00 cu.in
136. Total, cylinder-capacity	2,753 cm ³	168.00 cu.in
142. Compression ratio	8.3	
143. Volume of one combustion chamber	62.8 cm	
160. Flywheel (clean)	9.5 kg	
161. Flywheel with clutch (all turning parts)	16.5 kg	
164. Piston with rings and pin	0.54 kg	
181. Diameter of valves	44 mm	1.73 in
182. Max. valve lift	11 mm	0.43 in
186. Tappet clearance for checking timing (cold)	0.20 mm	
196. Diameter of valves	35 mm	1.38 in
197. Max. valve lift	11 mm	0.43 in
201. Tappet clearance for checking timing (cold)	0.25 mm	
220. Make of pump	BOSCH	
222. Model or type of pump	Electric	
223. Total number of injectors	6	
224. Location of injectors	Inlet manifold	
225. Minimum diameter of inlet pipe	32 mm	
250. Max. engine output	170 ps (type of horsepower: JIS) at 5,600 rpm	
251. Maximum rpm	5,600 output at that figure 170 ps	
252. Maximum torque	24.3 kg-m at 4,400 rpm	
253. Maximum speed of the car	205 km/hour	

255. Cam profile

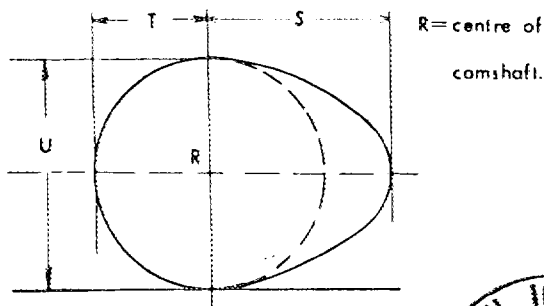

Inlet cam

S =	23.8 mm	0.94 inches
T =	16.5 mm	0.65 inches
U =	33.0 mm	1.30 inches

Exhaust cam

S =	23.8 mm	0.94 inches
T =	16.5 mm	0.65 inches
U =	33.0 mm	1.30 inches

- 262. Dia. of clutch plates
- 263. Dia. of linings, inside
- Dia. of linings, outside

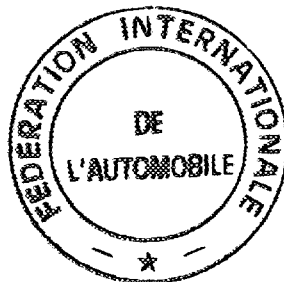

242	mm
150	mm
240	mm

REBORING DIMENSION

* Max bore	86.3 mm	3.40 inches
** Max capacity per cylinder	462 cm ³	28.19 cu.in
*** Max total cylinder capacity	2,772 cm ³	169.16 cu.in

COMBUSTION CHAMBER

* Volume of one combustion chamber of cylinder head	44.6 cm ³	2.72 cu.in
** Thickness of cylinder headgasket when compressed.	1.2 mm	



Photograph

L, Combustion chamber

M, Piston crown

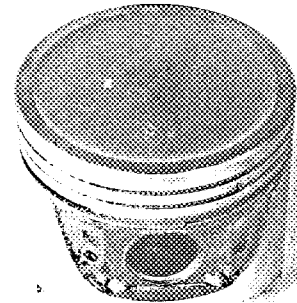
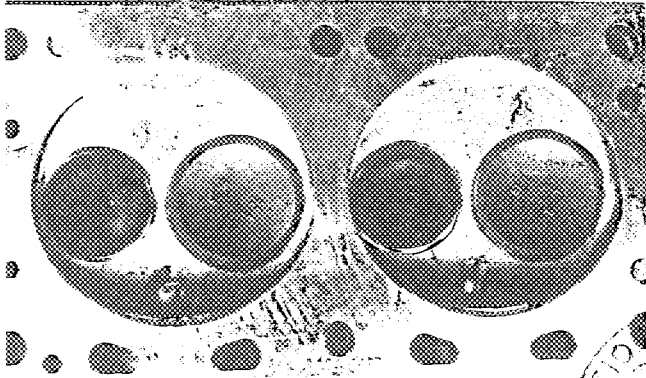

O, Engine in car with all accessories

P, Inlet manifold

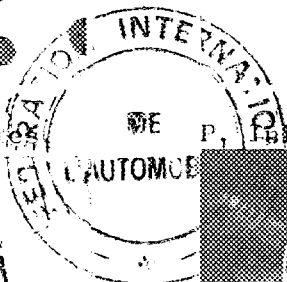
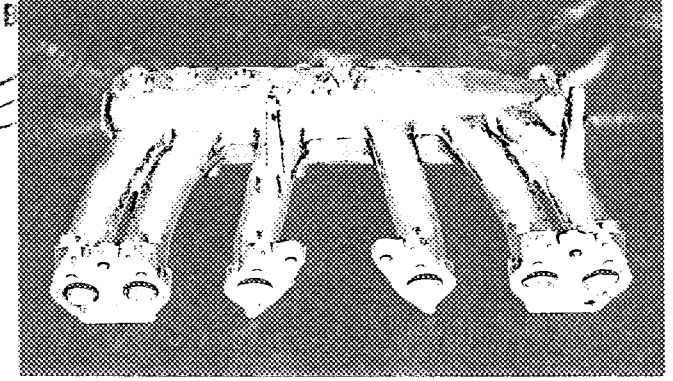

1. Head gasket
 2. Head cover
 3. Valve cover
 4. Head bolt
 5. Valve
 6. Piston
 7. Ring
 8. Crankshaft
 9. Connecting rod
 10. Oil pan
 11. Timing belt
 12. Water pump
 13. Fan
 14. Serpentine belt
 15. Drive pulley
 16. Idler pulley
 17. Tensioner pulley
 18. Accessory pulley
 19. Belt
 20. Pulley
 21. Bracket
 22. Nut
 23. Washer
 24. Pin
 25. Bolt
 26. Nut
 27. Washer
 28. Pin
 29. Bolt
 30. Nut
 31. Washer
 32. Pin
 33. Bolt
 34. Nut
 35. Washer
 36. Pin
 37. Bolt
 38. Nut
 39. Washer
 40. Pin
 41. Bolt
 42. Nut
 43. Washer
 44. Pin
 45. Bolt
 46. Nut
 47. Washer
 48. Pin
 49. Bolt
 50. Nut
 51. Washer
 52. Pin
 53. Bolt
 54. Nut
 55. Washer
 56. Pin
 57. Bolt
 58. Nut
 59. Washer
 60. Pin
 61. Bolt
 62. Nut
 63. Washer
 64. Pin
 65. Bolt
 66. Nut
 67. Washer
 68. Pin
 69. Bolt
 70. Nut
 71. Washer
 72. Pin
 73. Bolt
 74. Nut
 75. Washer
 76. Pin
 77. Bolt
 78. Nut
 79. Washer
 80. Pin
 81. Bolt
 82. Nut
 83. Washer
 84. Pin
 85. Bolt
 86. Nut
 87. Washer
 88. Pin
 89. Bolt
 90. Nut
 91. Washer
 92. Pin
 93. Bolt
 94. Nut
 95. Washer
 96. Pin
 97. Bolt
 98. Nut
 99. Washer
 100. Pin
 101. Bolt
 102. Nut
 103. Washer
 104. Pin
 105. Bolt
 106. Nut
 107. Washer
 108. Pin
 109. Bolt
 110. Nut
 111. Washer
 112. Pin
 113. Bolt
 114. Nut
 115. Washer
 116. Pin
 117. Bolt
 118. Nut
 119. Washer
 120. Pin
 121. Bolt
 122. Nut
 123. Washer
 124. Pin
 125. Bolt
 126. Nut
 127. Washer
 128. Pin
 129. Bolt
 130. Nut
 131. Washer
 132. Pin
 133. Bolt
 134. Nut
 135. Washer
 136. Pin
 137. Bolt
 138. Nut
 139. Washer
 140. Pin
 141. Bolt
 142. Nut
 143. Washer
 144. Pin
 145. Bolt
 146. Nut
 147. Washer
 148. Pin
 149. Bolt
 150. Nut
 151. Washer
 152. Pin
 153. Bolt
 154. Nut
 155. Washer
 156. Pin
 157. Bolt
 158. Nut
 159. Washer
 160. Pin
 161. Bolt
 162. Nut
 163. Washer
 164. Pin
 165. Bolt
 166. Nut
 167. Washer
 168. Pin
 169. Bolt
 170. Nut
 171. Washer
 172. Pin
 173. Bolt
 174. Nut
 175. Washer
 176. Pin
 177. Bolt
 178. Nut
 179. Washer
 180. Pin
 181. Bolt
 182. Nut
 183. Washer
 184. Pin
 185. Bolt
 186. Nut
 187. Washer
 188. Pin
 189. Bolt
 190. Nut
 191. Washer
 192. Pin
 193. Bolt
 194. Nut
 195. Washer
 196. Pin
 197. Bolt
 198. Nut
 199. Washer
 200. Pin
 201. Bolt
 202. Nut
 203. Washer
 204. Pin
 205. Bolt
 206. Nut
 207. Washer
 208. Pin
 209. Bolt
 210. Nut
 211. Washer
 212. Pin
 213. Bolt
 214. Nut
 215. Washer
 216. Pin
 217. Bolt
 218. Nut
 219. Washer
 220. Pin
 221. Bolt
 222. Nut
 223. Washer
 224. Pin
 225. Bolt
 226. Nut
 227. Washer
 228. Pin
 229. Bolt
 230. Nut
 231. Washer
 232. Pin
 233. Bolt
 234. Nut
 235. Washer
 236. Pin
 237. Bolt
 238. Nut
 239. Washer
 240. Pin
 241. Bolt
 242. Nut
 243. Washer
 244. Pin
 245. Bolt
 246. Nut
 247. Washer
 248. Pin
 249. Bolt
 250. Nut
 251. Washer
 252. Pin
 253. Bolt
 254. Nut
 255. Washer
 256. Pin
 257. Bolt
 258. Nut
 259. Washer
 260. Pin
 261. Bolt
 262. Nut
 263. Washer
 264. Pin
 265. Bolt
 266. Nut
 267. Washer
 268. Pin
 269. Bolt
 270. Nut
 271. Washer
 272. Pin
 273. Bolt
 274. Nut
 275. Washer
 276. Pin
 277. Bolt
 278. Nut
 279. Washer
 280. Pin
 281. Bolt
 282. Nut
 283. Washer
 284. Pin
 285. Bolt
 286. Nut
 287. Washer
 288. Pin
 289. Bolt
 290. Nut
 291. Washer
 292. Pin
 293. Bolt
 294. Nut
 295. Washer
 296. Pin
 297. Bolt
 298. Nut
 299. Washer
 300. Pin
 301. Bolt
 302. Nut
 303. Washer
 304. Pin
 305. Bolt
 306. Nut
 307. Washer
 308. Pin
 309. Bolt
 310. Nut
 311. Washer
 312. Pin
 313. Bolt
 314. Nut
 315. Washer
 316. Pin
 317. Bolt
 318. Nut
 319. Washer
 320. Pin
 321. Bolt
 322. Nut
 323. Washer
 324. Pin
 325. Bolt
 326. Nut
 327. Washer
 328. Pin
 329. Bolt
 330. Nut
 331. Washer
 332. Pin
 333. Bolt
 334. Nut
 335. Washer
 336. Pin
 337. Bolt
 338. Nut
 339. Washer
 340. Pin
 341. Bolt
 342. Nut
 343. Washer
 344. Pin
 345. Bolt
 346. Nut
 347. Washer
 348. Pin
 349. Bolt
 350. Nut
 351. Washer
 352. Pin
 353. Bolt
 354. Nut
 355. Washer
 356. Pin
 357. Bolt
 358. Nut
 359. Washer
 360. Pin
 361. Bolt
 362. Nut
 363. Washer
 364. Pin
 365. Bolt
 366. Nut
 367. Washer
 368. Pin
 369. Bolt
 370. Nut
 371. Washer
 372. Pin
 373. Bolt
 374. Nut
 375. Washer
 376. Pin
 377. Bolt
 378. Nut
 379. Washer
 380. Pin
 381. Bolt
 382. Nut
 383. Washer
 384. Pin
 385. Bolt
 386. Nut
 387. Washer
 388. Pin
 389. Bolt
 390. Nut
 391. Washer
 392. Pin
 393. Bolt
 394. Nut
 395. Washer
 396. Pin
 397. Bolt
 398. Nut
 399. Washer
 400. Pin
 401. Bolt
 402. Nut
 403. Washer
 404. Pin
 405. Bolt
 406. Nut
 407. Washer
 408. Pin
 409. Bolt
 410. Nut
 411. Washer
 412. Pin
 413. Bolt
 414. Nut
 415. Washer
 416. Pin
 417. Bolt
 418. Nut
 419. Washer
 420. Pin
 421. Bolt
 422. Nut
 423. Washer
 424. Pin
 425. Bolt
 426. Nut
 427. Washer
 428. Pin
 429. Bolt
 430. Nut
 431. Washer
 432. Pin
 433. Bolt
 434. Nut
 435. Washer
 436. Pin
 437. Bolt
 438. Nut
 439. Washer
 440. Pin
 441. Bolt
 442. Nut
 443. Washer
 444. Pin
 445. Bolt
 446. Nut
 447. Washer
 448. Pin
 449. Bolt
 450. Nut
 451. Washer
 452. Pin
 453. Bolt
 454. Nut
 455. Washer
 456. Pin
 457. Bolt
 458. Nut
 459. Washer
 460. Pin
 461. Bolt
 462. Nut
 463. Washer
 464. Pin
 465. Bolt
 466. Nut
 467. Washer
 468. Pin
 469. Bolt
 470. Nut
 471. Washer
 472. Pin
 473. Bolt
 474. Nut
 475. Washer
 476. Pin
 477. Bolt
 478. Nut
 479. Washer
 480. Pin
 481. Bolt
 482. Nut
 483. Washer
 484. Pin
 485. Bolt
 486. Nut
 487. Washer
 488. Pin
 489. Bolt
 490. Nut
 491. Washer
 492. Pin
 493. Bolt
 494. Nut
 495. Washer
 496. Pin
 497. Bolt
 498. Nut
 499. Washer
 500. Pin

